

123 Main St., City, ST 00000

Report: SAMPLE

**TABLE OF CONTENTS**

Images	1
Wall Area Diagram	2
Elevation Diagrams	3

REPORT DETAILS

Date:	03/04/2019
Report:	SAMPLE
Property:	123 Main St., City, ST 00000

WALL DETAILS

Total Wall Area: 5,044 sq ft

Calculation note: Garage door surface areas are subtracted from the total; window and door surface areas are not.

PREPARED FOR:

Contact: Your Name
Company: Your Company Name
Address: 123 Main St.
City, ST 00000
Phone: 555-555-5555

Satisfaction Guaranteed
www.eagleview.com/Guarantee.aspx

123 Main St., City, ST 00000

Report: SAMPLE

REPORT IMAGES

The following aerial images show different angles of this structure for your reference.



North View



South View



East View



West View

WALL AREA DIAGRAM

Total Wall Area = 5,044 sq ft

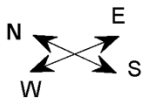
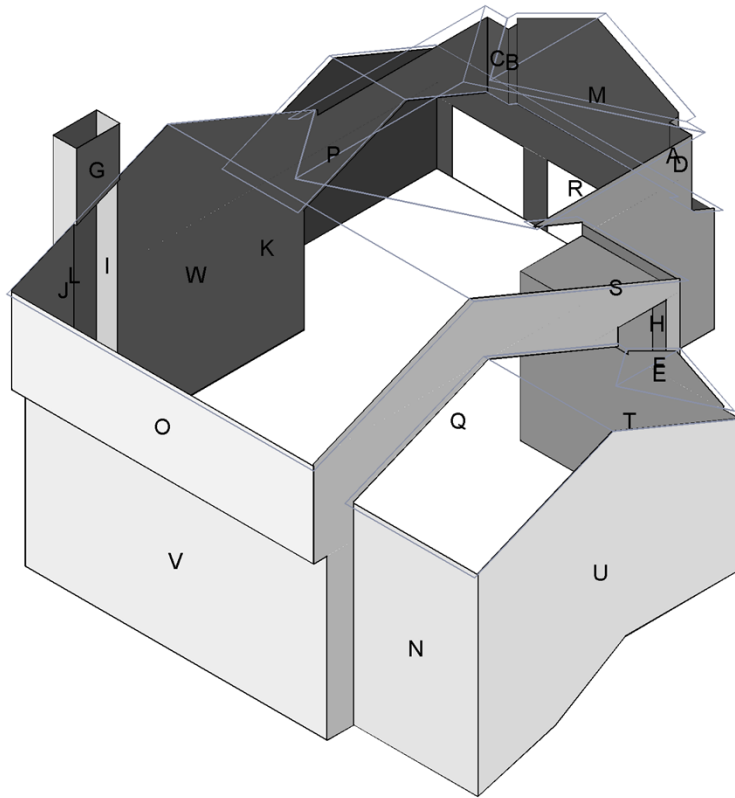

© 2019 Eagle View Technologies, Inc., All Rights Reserved.

Wall Area by Direction

North	East	South	West
B - 7.5 sq ft	C - 16.9 sq ft	A - 7.5 sq ft	E - 22.6 sq ft
F - 22.8 sq ft	D - 18.3 sq ft	G - 31.4 sq ft	J - 70.8 sq ft
L - 144.1 sq ft	H - 34.5 sq ft	Q - 343.8 sq ft	K - 93.6 sq ft
P - 322.8 sq ft	I - 70.3 sq ft	S - 394.6 sq ft	N - 297.4 sq ft
W - 865.8 sq ft	M - 188.2 sq ft	U - 588.2 sq ft	O - 318.7 sq ft
	R - 186.7 sq ft		V - 601.4 sq ft
	T - 395.7 sq ft		
1363 sq ft	910.6 sq ft	1365.5 sq ft	1404.5 sq ft

NORTH ELEVATION DIAGRAM

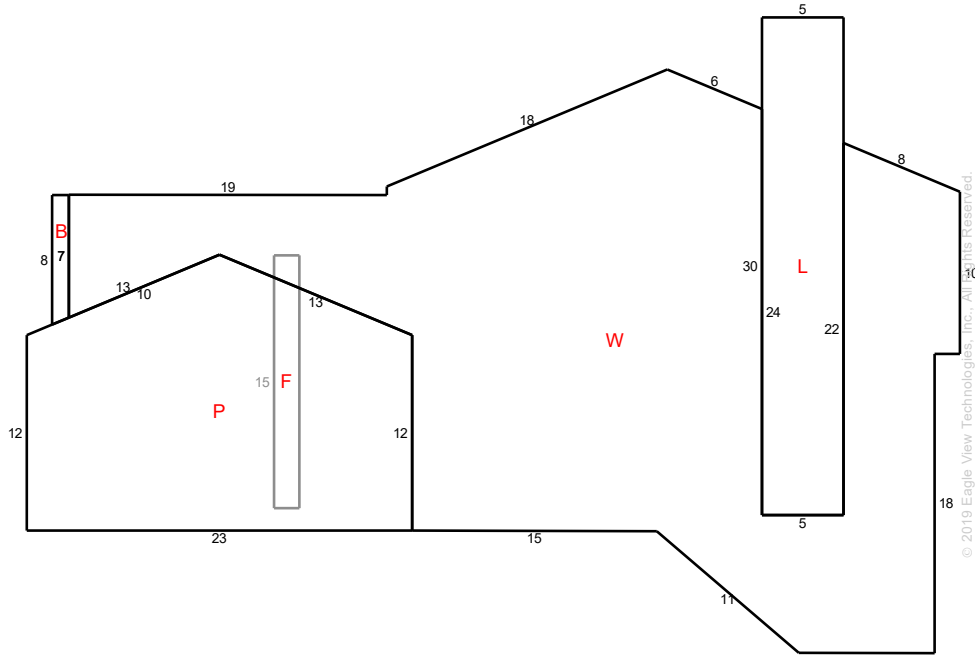

North Elevation Details

Wall	Wall Area	Notes
B	7.5	
F	22.8	
L	144.1	
P	322.8	
W	865.8	
Total	1363 sq ft	

Note: On-site verification of yellow shaded areas is needed. This diagram shows segment lengths rounded to the nearest whole number. The wall area in square feet (rounded to the nearest tenth) is based on the actual (non-rounded) value of each segment length. Windows and doors have not been subtracted from these measurements.

EAST ELEVATION DIAGRAM

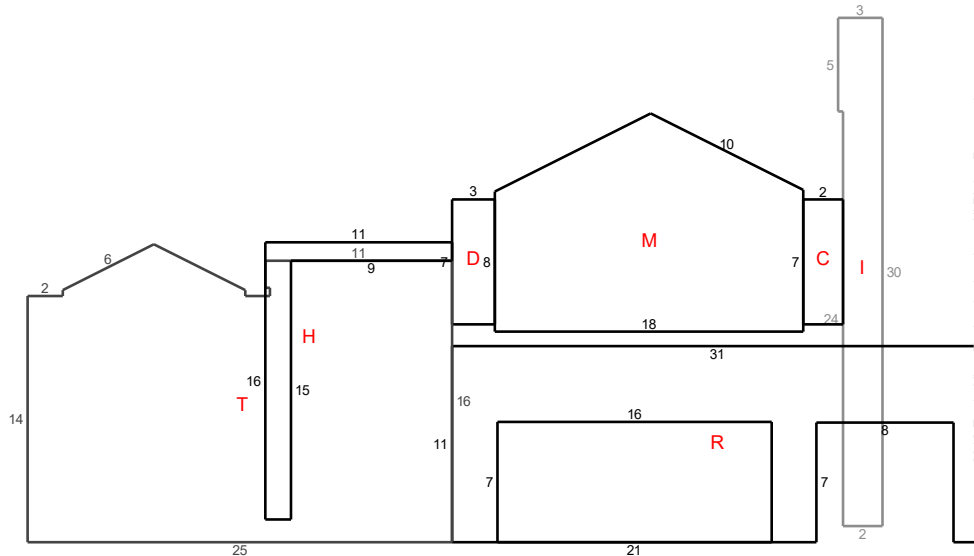

East Elevation Details

Wall	Wall Area	Notes
C	16.9	
D	18.3	
H	34.5	
I	70.3	
M	188.2	
R	186.7	
T	395.7	
Total	910.6 sq ft	

Note: On-site verification of yellow shaded areas is needed. This diagram shows segment lengths rounded to the nearest whole number. The wall area in square feet (rounded to the nearest tenth) is based on the actual (non-rounded) value of each segment length. Windows and doors have not been subtracted from these measurements.

SOUTH ELEVATION DIAGRAM

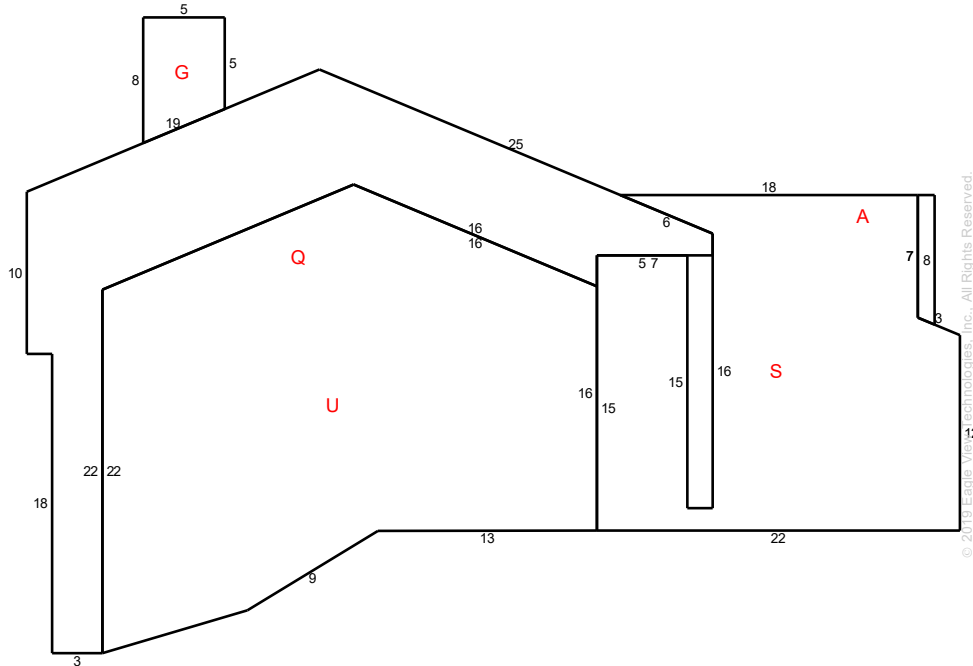

South Elevation Details

Wall	Wall Area	Notes
A	7.5	
G	31.4	
Q	343.8	
S	394.6	
U	588.2	
Total	1365.5 sq ft	

Note: On-site verification of yellow shaded areas is needed. This diagram shows segment lengths rounded to the nearest whole number. The wall area in square feet (rounded to the nearest tenth) is based on the actual (non-rounded) value of each segment length. Windows and doors have not been subtracted from these measurements.

WEST ELEVATION DIAGRAM

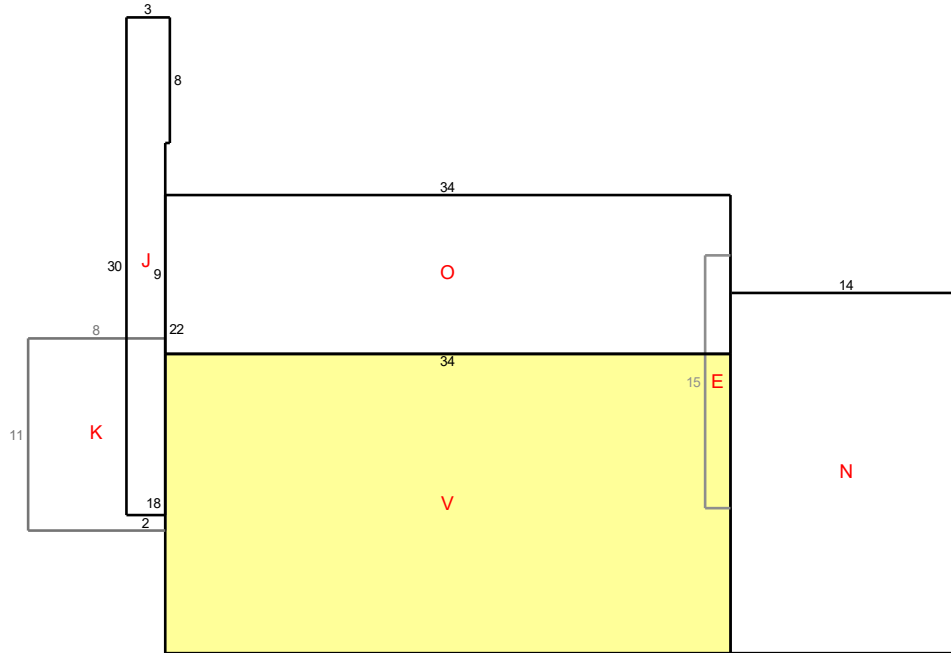

© 2019 Eagle View Technologies, Inc., All Rights Reserved.

West Elevation Details

Wall	Wall Area	Notes
E	22.6	
J	70.8	
K	93.6	
N	297.4	
O	318.7	
V	601.4	
Total	1404.5 sq ft	

Note: On-site verification of yellow shaded areas is needed. This diagram shows segment lengths rounded to the nearest whole number. The wall area in square feet (rounded to the nearest tenth) is based on the actual (non-rounded) value of each segment length. Windows and doors have not been subtracted from these measurements.