

123 Main St., City, ST 00000

Report: SAMPLE

Report Content

Images	1
Wall Area Diagram	4
Elevation Diagrams.....	5

Prepared For

Contractor: Your Name
 Company: Your Company Name
 Address: 123 Main St. City, ST 00000
 Phone: 555-555-5555

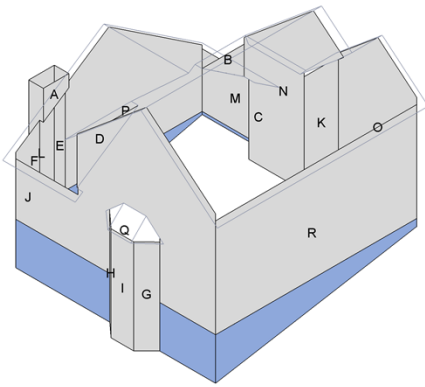

● Siding
 ● Masonry

© 2021 Eagle View Technologies, Inc., All Rights Reserved.

Wall Details

Wall Area including Windows & Doors	=	4056.1 ft ²
Total Siding Area	=	3491.1 ft ²
Total Masonry Area	=	565.0 ft ²

***Calculation Note: Garage door surface areas are subtracted from the total; window and door surface areas are not.**



Satisfaction Guaranteed
www.eagleview.com/Guarantee.aspx

123 Main St., City, ST 00000

Report: SAMPLE

IMAGES – TOP VIEW

Top Image



123 Main St., City, ST 00000

Report: SAMPLE

IMAGES – NORTH & SOUTH

North Side



South Side



123 Main St., City, ST 00000

Report: SAMPLE

IMAGES – EAST & WEST

East Side



West Side



123 Main St., City, ST 00000

Report: SAMPLE

WALL AREA DIAGRAM

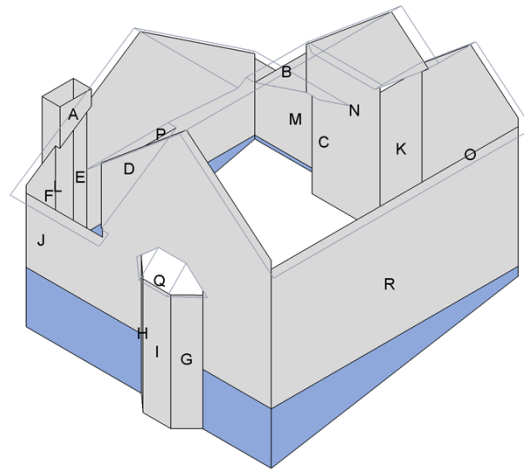

© 2021 Eagle View Technologies, Inc., All Rights Reserved.

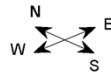

● Siding
● Masonry

North

Wall	Siding Wall Area (ft ²)	Masonry Wall Area (ft ²)
D	46.5	0.0
L	133.3	0.0
K	128.7	0.0
B	21.8	0.0
P	478.2	95.8
J	58.5	36.2
Total	867.0	132.0

East

Wall	Siding Wall Area (ft ²)	Masonry Wall Area (ft ²)
E	57.6	0.0
N	320.2	0.0
O	351.2	9.4
M	133.1	6.8
Total	862.1	16.2

South

Wall	Siding Wall Area (ft ²)	Masonry Wall Area (ft ²)
C	45.3	0.0
A	19.8	0.0
R	737.5	182.8
Total	802.6	182.8

West

Wall	Siding Wall Area (ft ²)	Masonry Wall Area (ft ²)
F	61.7	0.0
G	64.7	0.0
I	79.0	0.0
H	67.8	0.0
Q	686.2	234.0
Total	959.4	234.0

123 Main St., City, ST 00000

Report: SAMPLE

NORTH ELEVATION DIAGRAM

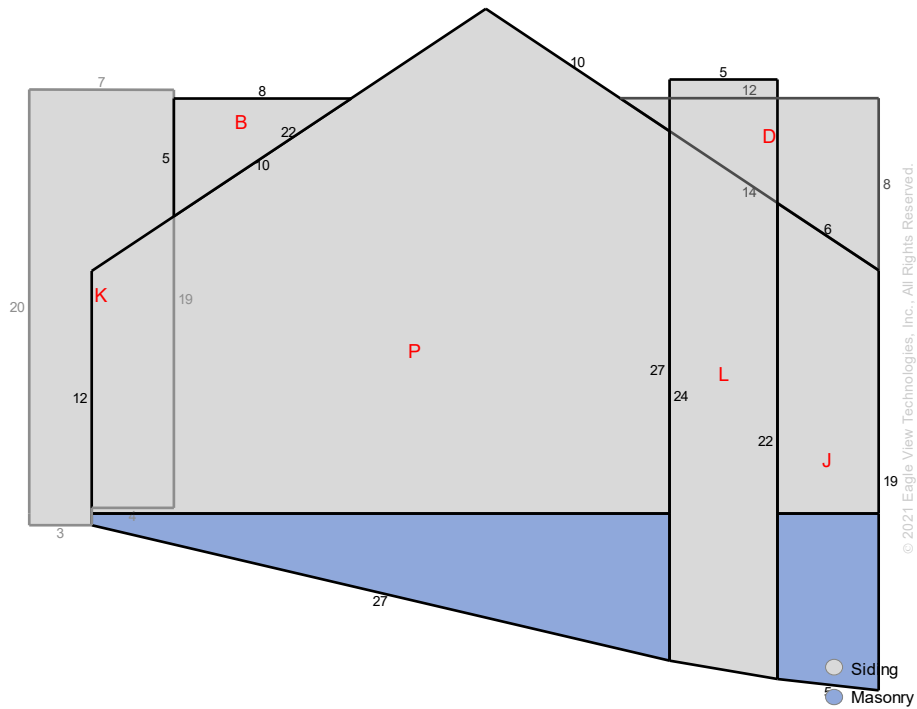

Wall	Siding Wall Area (ft ²)	Masonry Wall Area (ft ²)
D	46.5	0.0
L	133.3	0.0
K	128.7	0.0
B	21.8	0.0
P	478.2	95.8
J	58.5	36.2
Total	867.0	132.0

Note: On-site verification of yellow shaded areas is needed. This diagram shows segment lengths rounded to the nearest whole number. The wall area in square feet (rounded to the nearest tenth) is based on the actual (non-rounded) value of each segment length. Windows and doors have not been subtracted from these measurements.

123 Main St., City, ST 00000

Report: SAMPLE

EAST ELEVATION DIAGRAM

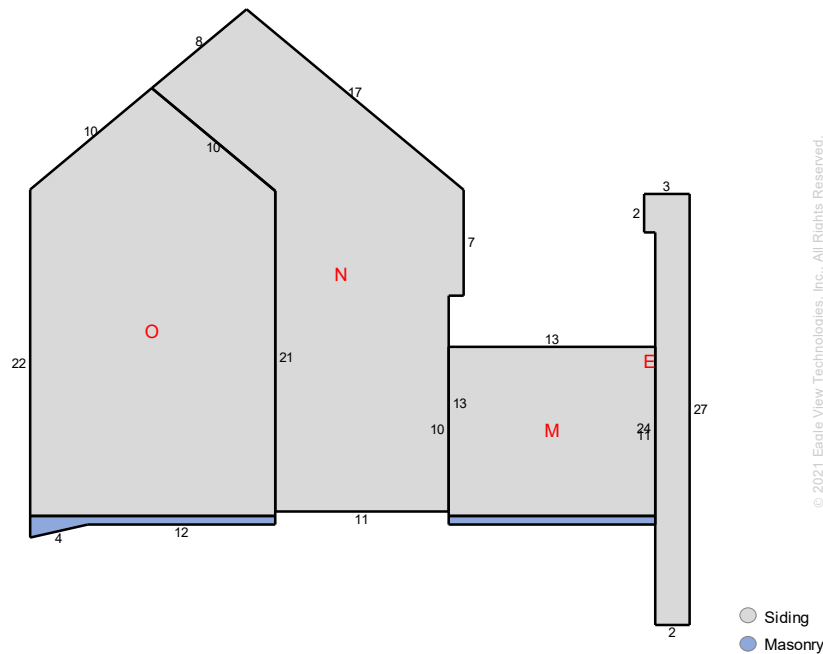

Wall	Siding Wall Area (ft ²)	Masonry Wall Area (ft ²)
E	57.6	0.0
N	320.2	0.0
O	351.2	9.4
M	133.1	6.8
Total	862.1	16.2

Note: On-site verification of yellow shaded areas is needed. This diagram shows segment lengths rounded to the nearest whole number. The wall area in square feet (rounded to the nearest tenth) is based on the actual (non-rounded) value of each segment length. Windows and doors have not been subtracted from these measurements.

123 Main St., City, ST 00000

Report: SAMPLE

SOUTH ELEVATION DIAGRAM

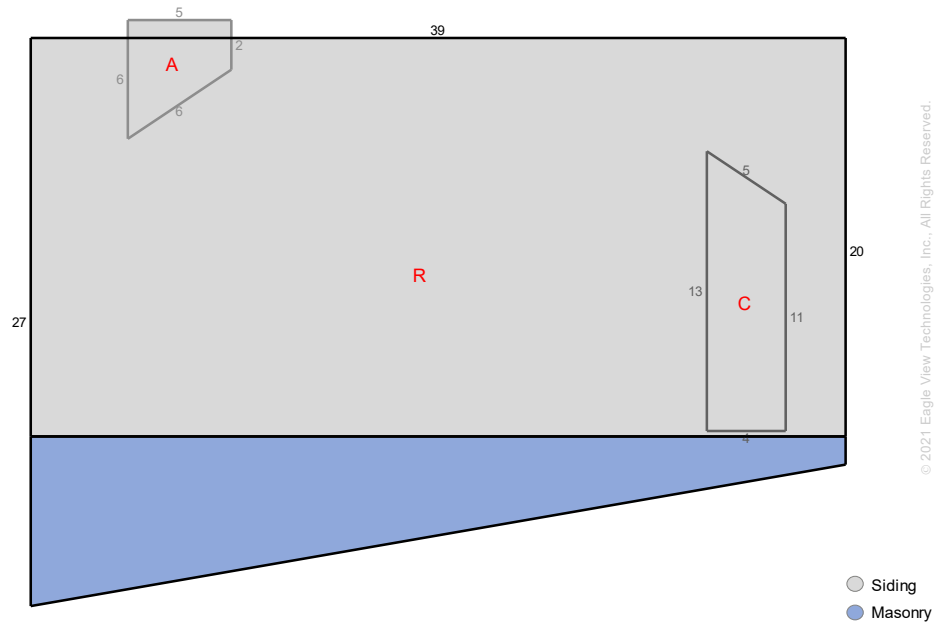

Wall	Siding Wall Area (ft ²)	Masonry Wall Area (ft ²)
C	45.3	0.0
A	19.8	0.0
R	737.5	182.8
Total	802.6	182.8

Note: On-site verification of yellow shaded areas is needed. This diagram shows segment lengths rounded to the nearest whole number. The wall area in square feet (rounded to the nearest tenth) is based on the actual (non-rounded) value of each segment length. Windows and doors have not been subtracted from these measurements.

123 Main St., City, ST 00000

Report: SAMPLE

WEST ELEVATION DIAGRAM

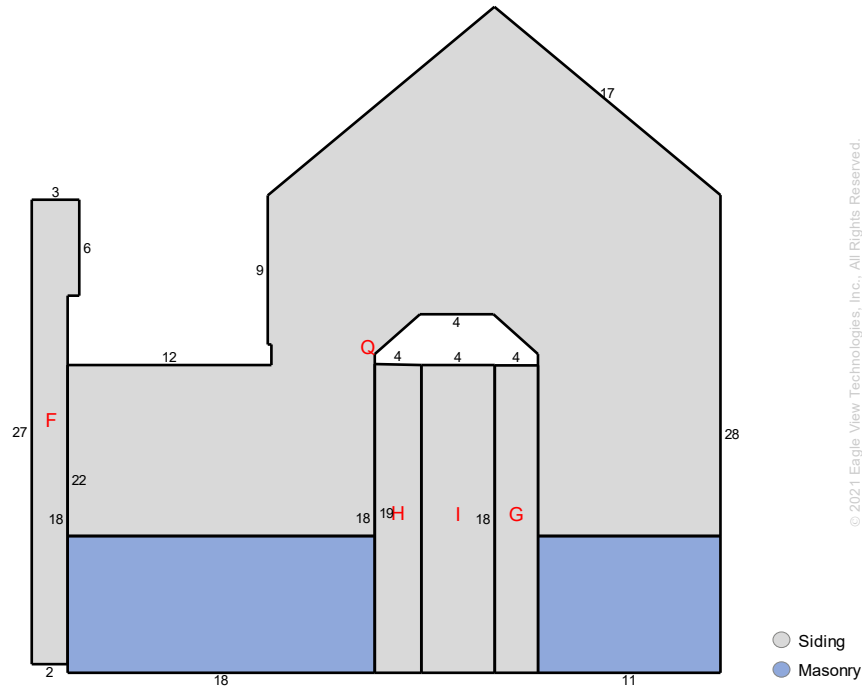

Wall	Siding Wall Area (ft ²)	Masonry Wall Area (ft ²)
F	61.7	0.0
G	64.7	0.0
I	79.0	0.0
H	67.8	0.0
Q	686.2	234.0
Total	959.4	234.0

Note: On-site verification of yellow shaded areas is needed. This diagram shows segment lengths rounded to the nearest whole number. The wall area in square feet (rounded to the nearest tenth) is based on the actual (non-rounded) value of each segment length. Windows and doors have not been subtracted from these measurements.